

# SILVERLINE SINGLE SCISSORS

## BETTER MANUAL HANDLING

### TECHNICAL SPECIFICATIONS

- > LIFT CAPACITY: FROM 1000 - 2000 KG
- > TRAVEL: 810 MM.
- > CLOSED HEIGHT: 200 MM.
- > LENGTH: 1300 MM.
- > WIDTH: 800 - 1000 MM.
- > POWER SUPPLY: 3x400 V/50 HZ+PE
- > CE MARKED
- > AVAILABLE IN RAL COLOUR 7031
- > 2 COMPONENT POLYURETHANE PAINT (RAL)
- > RECOMMENDED USE: MAX 5-6 LIFTS, 8 HOURS A DAY  
- INQUIRE FOR MORE INTENSE USE
- > 2 SAFETY LOCKS FOR MAINTENANCE
- > SAFETY TRIP BAR IN ALUMINIUM



Our Silverline series sets a new standard for non-bespoke lifting tables. You get Danish craftsmanship at a low price and easy access to spareparts. A lifting table can provide a solution whenever heavy lifting, awkward working positions and height variations is a challenge. The Silverline lifting tables are available in painted steel and have three types of accessories that can be added to the lifting table:

1: Upper/lower limit switch

2: Mobility wheel kit

3: Truck frame

See the standard Silverline models on the next page or find more information at [www.translyft.com](http://www.translyft.com)



The Silverline is perfect as a work table for heavy objects.



A lifting table eases manual handling and optimizes efficiency.



The Silverline is delivered in a wear resistant RAL 7011 paint finish.

Type/Capacity kg	Travel mm	Closed height mm	Total raised height mm	Length mm	Width mm	Lift time sec	Motor kW	Weight kg
SL 1000 B	810	200	1010	1300	800	16	0,75	160
SL 1000 F	810	200	1010	1300	1000	18	0,75	170
SL 2000	810	200	1010	1300	800	21	0,75	240
SL 2000 F	810	200	1010	1300	1000	23	0,75	250

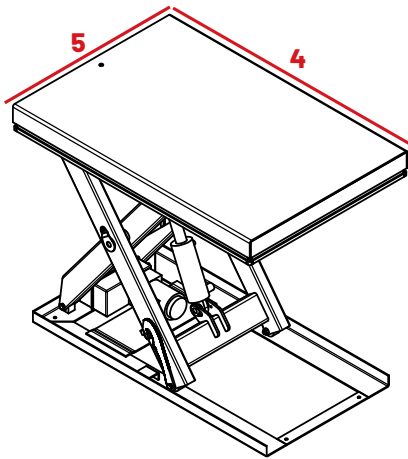

Capacity	Highest load capability (when loaded correctly)
Travel (1)	Travel from closed height to top position
Closed height (2)	Height at lowest position
Total raised height (3)	Height at top position
Length (4)	Platform length
Width (5)	Platform width
Lift time	Time in sec. to top position
Motor	Size of motor
Weight	Weight of table

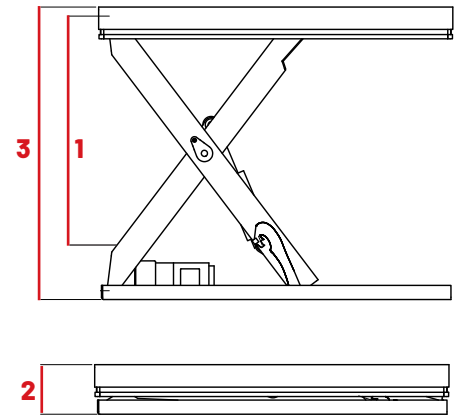

**We know that every lift is unique and that all workspaces are different.**

Contact us at +45 9886 4900 to find the perfect lifting table for you.